

PCS Series - Page C2

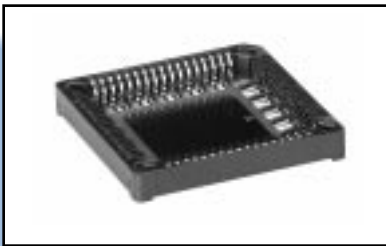

PCSZT Series - Page C4



PCS-SMU Series - Page C6



SOJ Series - Page C8

PLCC/SOJ

PCS Series *Sockets for PLCC Packages*



PCS-068A-1

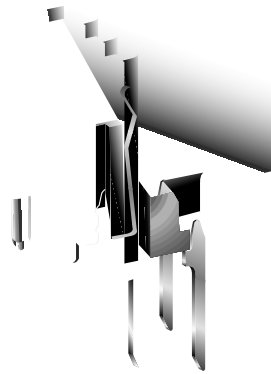

C

FEATURES:

The Augat PCS Series Chip Carrier sockets accepts Jedec Type "A" plastic leaded chip carriers on .050" (1.27) centers. These dependable sockets combine positive retention of the package with high normal force to insure outstanding electrical and mechanical performance. The solder tail design allows through-hole board patterns on .100" (2.54) grid.

- High Normal force, 200 grams (7.1 oz.) min.
- Internal standoff insures proper positioning of chip carrier in socket
- Visual aids external to socket assure easy registration to printed wiring board
- Easy access for probing installed chip carrier
- Standoffs and four drain holes aid in cleaning
- PLCC Extraction Tool TX8136-20/84 PCS, see page J3
- Accepts JEDEC PLCC's MO-047 AA-AH (20-84), MO-052 AE (32 RECT)
-  Recognized under the Component Program of Underwriters Laboratories, Inc. file no. E111362

MATERIAL SPECIFICATIONS:

Insulator PPS, UL rated 94V-0
 Contact Phosphor bronze
 Plating Tin/lead

PERFORMANCE SPECIFICATIONS:

MECHANICAL

Vibration Passed MIL-STD-1344, Method 2005.1, Condition II, 10 G's
 Shock Passed MIL-STD-1344, Method 2004.1, Condition A, 50 G's
 Durability 50 Cycles minimum
 Normal Force 200 Grams (7.1 oz.) minimum when mated to nominal size PLCC device
 Mating Force 310 Grams (11.0 oz.) per line maximum when mated to maximum size PLCC device
 Unmating Force 31 Grams (1.1 oz) per line minimum when mated to minimum size PLCC device
 Solderability Passed MIL-STD-202, Method 208
 Contact Retention in Plastic 2.0 Lbs. per line minimum

ELECTRICAL

Contact Resistance 30 Milliohms max.
 Contact Rating 1 Amp
 Capacitance 1 pF max. @ 1 kHz, MIL-STD-202, Method 305 (contact to contact)
 Insulation Resistance .. 1×10^4 Megohms per MIL-STD-1344, Method 3003.1
 Dielectric Withstanding Voltage 600 VAC per MIL-STD-1344, Method 3001.1

ENVIRONMENTAL

Humidity Passed MIL-STD-1344, Method 1002.2, Type II
 Operation Temperature .. -55°C to +105°C

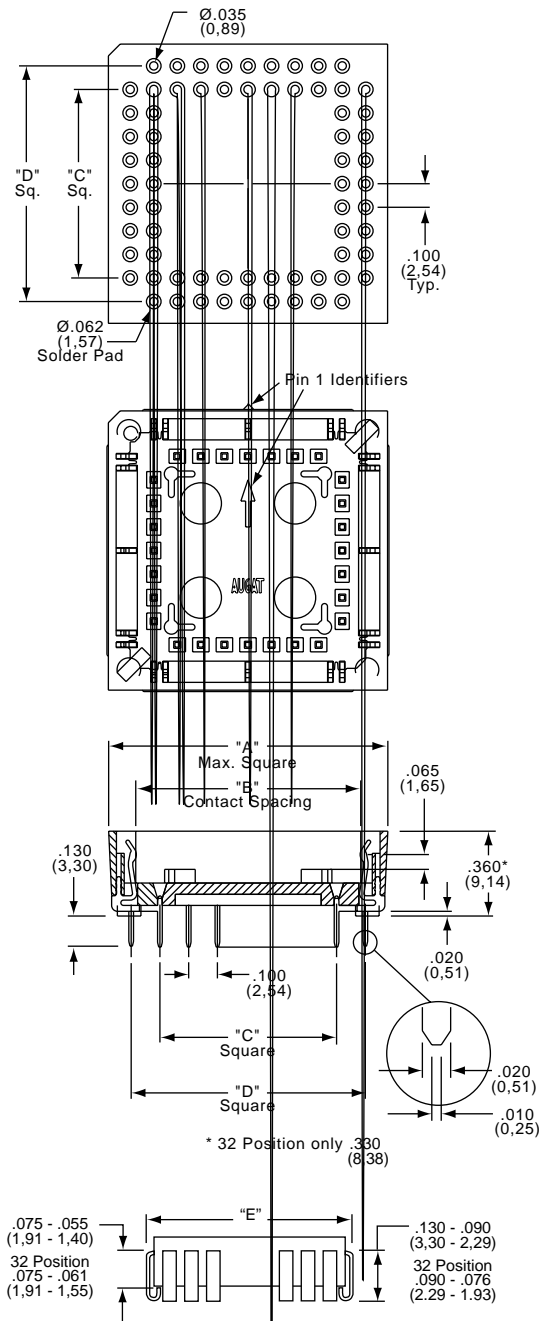
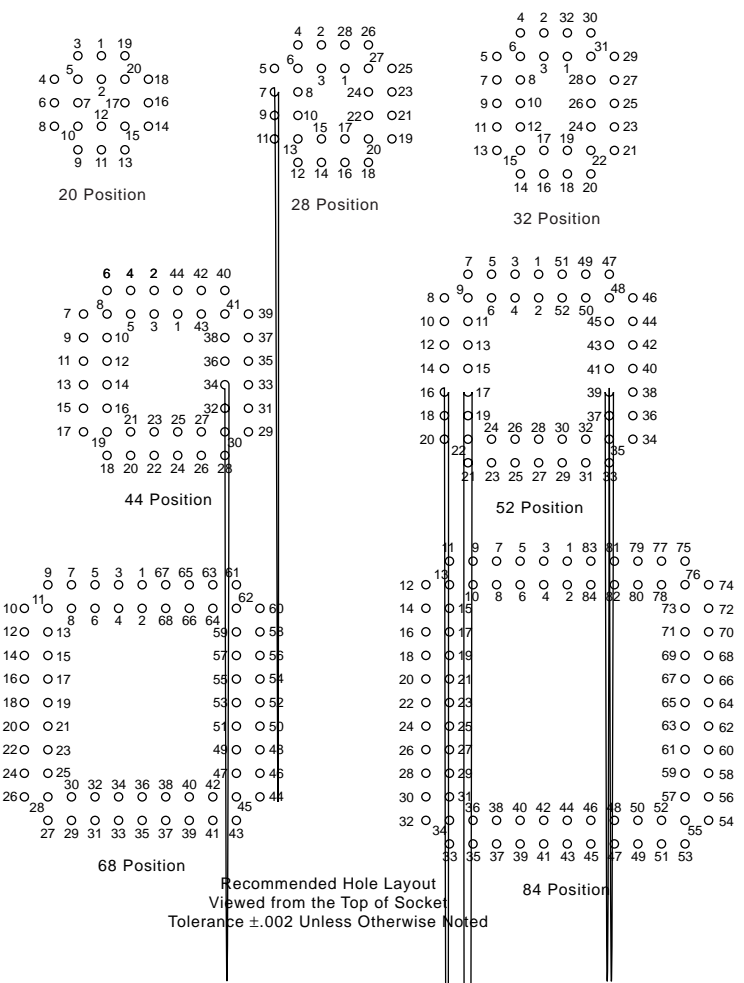

STANDARD CONFIGURATIONS

Part Number	Number of Contacts	A	B*	C	D	E
PCS-020A-1	20	.590 (14.98)	.360 (9.14)	.200 (5.08)	.400 (10.16)	.395/.385 (10.03/9.78)
PCS-028A-1	28	.690 (17.52)	.460 (11.68)	.300 (7.62)	.500 (12.70)	.495/.485 (12.57/12.32)
PCS-044A-1	44	.890 (22.60)	.660 (16.76)	.500 (12.70)	.700 (17.78)	.695/.685 (17.65/17.40)
PCS-052A-1	52	.990 (25.15)	.760 (19.30)	.600 (15.24)	.800 (20.32)	.795/.785 (20.19/19.94)
PCS-068A-1	68	1.190 (30.22)	.960 (24.46)	.800 (20.32)	1.000 (25.40)	.995/.985 (25.27/25.02)
PCS-084A-1	84	1.390 (35.31)	1.160 (29.54)	1.000 (25.40)	1.200 (30.48)	1.195/1.185 (30.35/30.10)

* Dimension B ± .010 (0,25)

32 POSITION RECTANGULAR

Part Number	Number of Contacts	A		B*		C		D		E	
		Long Side	Short Side	Long Side	Short Side	Long Side	Short Side	Long Side	Short Side	Long Side	Short Side
PCS-032A-1	32	.790 (20,07)	.690 (17,53)	.564 (14,33)	.464 (11,79)	.400 (10,16)	.300 (7,62)	.600 (15,24)	.500 (12,70)	.595/.585 (15,11/14,86)	.495/.485 (12,57/12,32)

* Dimension B ± .010 (0,25)

Need more technical information?
Consult your Thomas & Betts sales office listed on the back cover

PCSZT Series *Sockets for PLCC Packages*



C

FEATURES:

The Augat PCSZT Series Low Profile Chip Carrier sockets accept plastic leaded chip carriers on .050" (1,27) centers. These dependable sockets combine positive retention of the package with high normal force to insure outstanding electrical and mechanical performance.

Two piece insulator construction leaves terminal circuitry unexposed on the bottom of the socket. The solder tail design allows thru-hole board patterns on .100" (2,54) grid.

- High normal force, 150 grams (5.3 oz.) min.
- Internal standoff insures proper positioning of chip carrier in socket
- Visual aids external to socket assure easy registration to printed wiring board
- Easy access for probing installed chip carrier
- Standoffs and four drain holes aid in cleaning
- PLCC Extraction Tool TX8136-20/84 PCS, see page J3

MATERIAL SPECIFICATIONS:

Insulator PPS, UL rated 94V-0
Contact Phosphor bronze
Plating Tin/lead

PERFORMANCE SPECIFICATIONS:

ELECTRICAL

Contact Resistance ... 30 Milliohms max.
Contact Rating 1 Amp
Capacitance 1 pF max. @ 1 kHz, MIL-STD-202, Method 305
(contact to contact)
Insulation Resistance .. 1×10^{-4} Megohms per MIL-STD-1344,
Method 3003.1
Dielectric Withstanding
Voltage 600 VAC Per MIL-STD-1344, Method 3001.1

ENVIRONMENTAL

Humidity Passed MIL-STD-1344, Method 1002.2, Type II
Operation Temperature .. -55°C to +105°C

Sockets for PLCC Packages **PCSZT Series**

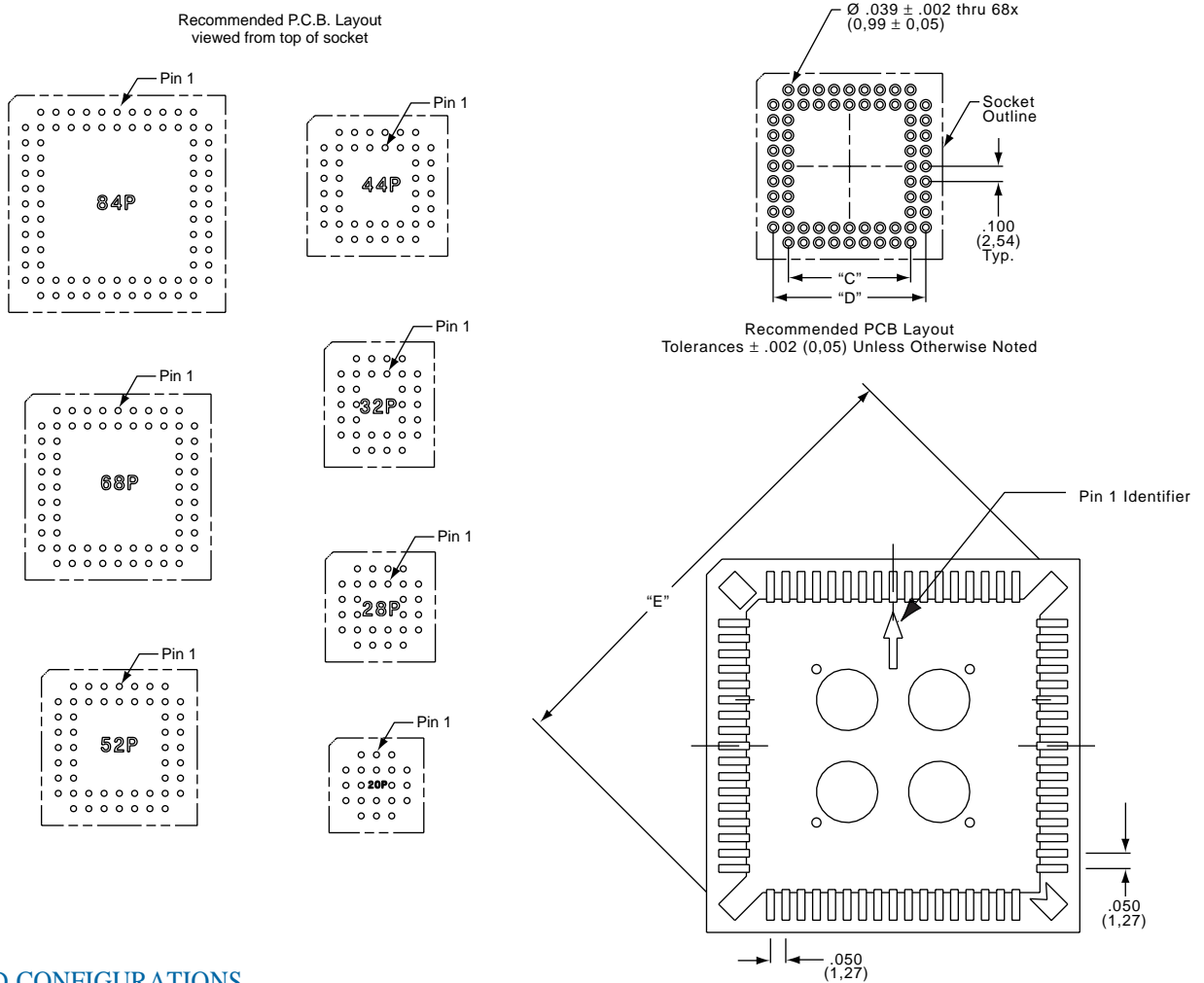

STANDARD CONFIGURATIONS

Part Number	Number of Contacts	A	B*	C	D	E
PCSZT-020A-1	20	.625 (15,87)	.350 (8,89)	.200 (5,08)	.400 (10,16)	.705 (17,90)
PCSZT-028A-1	28	.725 (18,41)	.456 (11,58)	.300 (7,62)	.500 (12,70)	.855 (21,72)
PCSZT-044A-1	44	.920 (23,37)	.668 (16,97)	.500 (12,70)	.700 (17,77)	1.150 (29,21)
PCSZT-052A-1	52	1.025 (26,03)	.755 (19,17)	.600 (15,24)	.800 (20,32)	1.255 (31,87)
PCSZT-068A-1	68	1.230 (31,24)	.951 (24,15)	.800 (20,32)	1.000 (25,40)	1.575 (40,00)
PCSZT-084A-1	84	1.425 (36,19)	1.168 (29,66)	1.000 (25,40)	1.200 (30,48)	1.860 (47,24)

* Dimension B ± .010 (0,25)

32 POSITION RECTANGULAR

Part Number	Number of Contacts	A		B*		C		D		E
		Long Side	Short Side	Long Side	Short Side	Long Side	Short Side	Long Side	Short Side	
PCSZT-032A-1	32	.825 (20,95)	.725 (18,41)	.556 (14,12)	.456 (11,58)	.400 (10,16)	.300 (7,62)	.600 (15,24)	.500 (12,70)	.950 (24,13)

* Dimension B ± .010 (0,25)

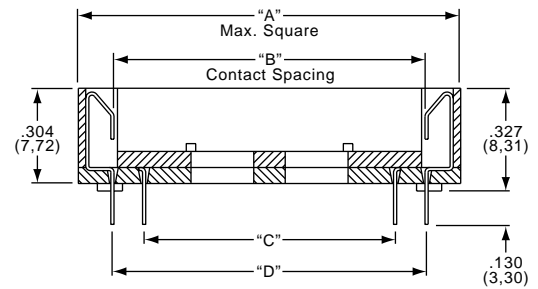

Need more technical information?

Consult your Thomas & Betts
sales office listed on the back cover

PCS SMU Series *Ultra Low Profile Surface Mount PLCC Sockets*



PCS-068SMU-11

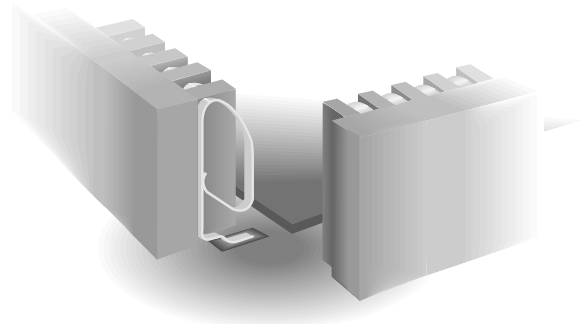

C

FEATURES:

The Augat SMU Series Surface Mount Chip carrier sockets are an "Ultra" low profile, .175" (4.45) for JEDEC dimensioned PLCC devices. The lower profile is to accommodate height packaging restrictions in high density disk drive and laptop applications. With a PCB footprint which matches PLCC device and an open insulator design to facilitate placement and inspection, the Augat SMU Series meets your high density packaging needs.

- Accepts JEDEC PLCC's MO-047 AA-AH (20-84), and MO-052 AE (32 RECT)
- High temperature insulator material compatible with vapor phase and infrared reflow processing
- Visual markings internal and external to socket assure easy registration as well as the option of locating posts
- Open insulator design aids in placement, inspection and cleaning of solder joints
-  UL recognition under Component Program of Underwriters Laboratories, Inc. file no. E111362 pending
- PLCC Extraction Tool TX8136-20/84PCS

MATERIAL SPECIFICATIONS:

Insulator PPS, UL rated 94V-0
 Contact Phosphor bronze
 Plating Tin/lead

PERFORMANCE SPECIFICATIONS:

MECHANICAL

Vibration Passed MIL-STD-1344, Method 2005.1, Condition II, 10 G's
 Shock Passed MIL-STD-1344, Method 2004.1, Condition A, 50 G's
 Durability 25 Cycles minimum
 Normal Force 150 Grams (5.29 oz.) per line minimum
 Mating Force 200 Grams (7.05 oz.) per line maximum
 Unmating Force 33 Grams (1.17 oz.) per line minimum
 Solderability Passed MIL-STD-202, Method 208
 Contact Retention
 in Plastic 454 Grams (16 oz.) per line minimum

ELECTRICAL

Low Level
 Contact Resistance ... 20 Milliohms max. per MIL-STD-1344, Method 3002
 Contact Rating 1 Amp
 Capacitance 2 pF max. @ 1 kHz, MIL-STD-202, Method 305
 Insulation Resistance ... 10,000 Megohms minimum @ 100 VDC per MIL-STD-1344, Method 3003.1
 Dielectric Withstanding
 Voltage 600 VAC per MIL-STD-1344, Method 3001.1

ENVIRONMENTAL

Humidity Passed MIL-STD-1344, Method 1002.2, Type II
 Operation Temperature .. -55°C to +105°C
 Resistance to
 Solder Heat Infrared reflow 230 °C, duration 15 seconds

Ultra Low Profile Surface Mount PLCC Sockets PCS-SMU Series

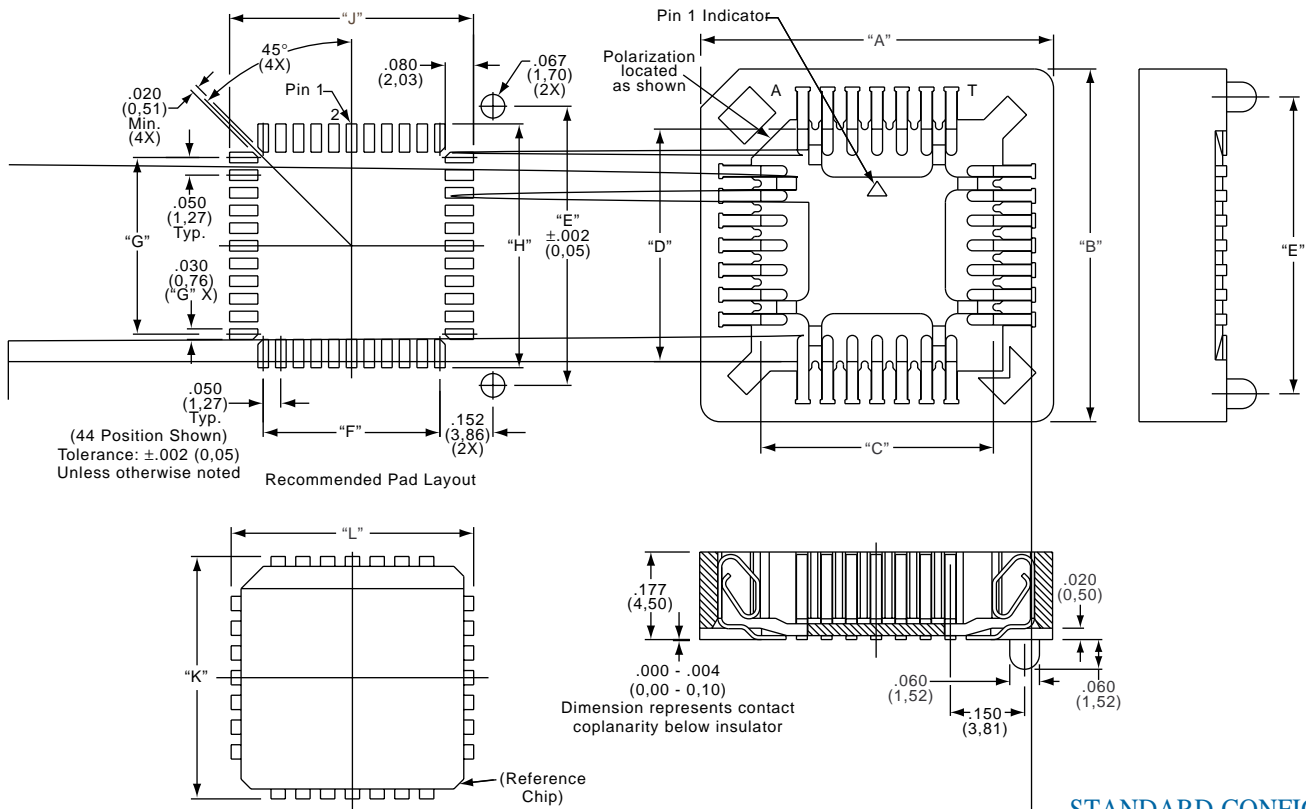

STANDARD CONFIGURATIONS

No. of Contacts	A*	B*	C	D	E	F	G	H	J	K	L
20	.613 (15,57)	.613 (15,57)	.364 (9,24)	.364 (9,24)	.500 (12,70)	.200 (5,08)	.200 (5,08)	.404 (10,26)	.404 (10,26)	.390 (9,90)	.390 (9,90)
28	.713 (18,11)	.713 (18,11)	.466 (11,83)	.466 (11,83)	.600 (15,24)	.300 (7,62)	.300 (7,62)	.504 (12,80)	.504 (12,80)	.490 (12,44)	.490 (12,44)
32	.713 (18,11)	.813 (20,65)	.466 (11,83)	.566 (14,37)	.700 (17,78)	.300 (7,62)	.400 (10,16)	.604 (15,34)	.504 (12,80)	.590 (14,98)	.490 (12,44)
44	.913 (23,19)	.913 (23,19)	.662 (16,81)	.662 (16,81)	.800 (20,32)	.500 (12,70)	.500 (12,70)	.704 (17,88)	.704 (17,88)	.690 (17,52)	.690 (17,52)
52	1.013 (25,73)	1.013 (25,73)	.766 (19,45)	.766 (19,45)	.900 (22,86)	.600 (15,24)	.600 (15,24)	.804 (20,42)	.804 (20,42)	.790 (20,06)	.790 (20,06)
68	1.213 (30,81)	1.213 (30,81)	.967 (24,56)	.967 (24,56)	1.100 (27,94)	.800 (20,32)	.800 (20,32)	1.004 (25,50)	1.004 (25,50)	.990 (25,14)	.990 (25,14)
84	1.413 (35,89)	1.413 (35,89)	1.164 (29,56)	1.164 (29,56)	1.300 (33,02)	1.000 (25,40)	1.000 (25,40)	1.204 (30,58)	1.204 (30,58)	1.190 (30,22)	1.190 (30,22)

* Dimension A & B ± .010 (0,25)

PART NUMBERS

Part Number	Number of Contacts	Locating Posts	T-Tape & Reel Packaging	Part Number	Number of Contacts	Locating Posts	T-Tape & Reel Packaging
PCS-020SMU-11T	20	Without	With	PCS-052SMU-11T	52	Without	With
PCS-020SMU-11	20	Without	Without	PCS-052SMU-11	52	Without	Without
PCS-020SMU-12T	20	With	With	PCS-052SMU-12T	52	With	With
PCS-020SMU-12	20	With	Without	PCS-052SMU-12	52	With	Without
PCS-028SMU-11T	28	Without	With	PCS-068SMU-11T	68	Without	With
PCS-028SMU-11	28	Without	Without	PCS-068SMU-11	68	Without	Without
PCS-028SMU-12T	28	With	With	PCS-068SMU-12T	68	With	With
PCS-028SMU-12	28	With	Without	PCS-068SMU-12	68	With	Without
PCS-032SMU-11T	32	Without	With	PCS-084SMU-11T	84	Without	With
PCS-032SMU-11	32	Without	Without	PCS-084SMU-11	84	Without	Without
PCS-032SMU-12T	32	With	With	PCS-084SMU-12T	84	With	With
PCS-032SMU-12	32	With	Without	PCS-084SMU-12	84	With	Without
PCS-044SMU-11T	44	Without	With				
PCS-044SMU-11	44	Without	Without				
PCS-044SMU-12T	44	With	With				
PCS-044SMU-12	44	With	Without				

Need more technical information?

Consult your Thomas & Betts sales office listed on the back cover

SOJ Socket



165-200005-03



FEATURES:

Augat's new SOJ Socket provides the user an easy means of socketing their SOJ devices. These full featured devices are available in a variety of sizes.

- Sizes range from 24 to 42 positions
- .400" (10,16) and .300" (7,62) centerlines
- High normal force contact insure long term reliability
- High temperature plastic
- Tube and tape & reel packaging
- High normal force for excellent IC retention and contact reliability
- Open body allows inspection of solder joints
- High temperature insulator body is compatible with vapor phase and infrared reflow processing

MATERIAL SPECIFICATIONS:

Contact Phosphor bronze
Insulator PPS UL rated 94V-0
Plating Tin/lead

PERFORMANCE SPECIFICATIONS:

ELECTRICAL

Contact Resistance ... 20 Milliohms max. per MIL-STD-1344, Method 3002

Contact Rating 1 Amp

Capacitance 1 pF max. @ 1 kHz, MIL-STD-202, Method 305 (contact to contact)

Insulation Resistance 10,000 Megohms minimum @ 500 VDC per MIL-STD-1344, Method 3003.1

Dielectric Withstanding

Voltage 600 VDC per MIL-STD-1344, Method 3001.1

ENVIRONMENTAL

Humidity Passed MIL-STD-1344, Method 1002.2, Type II

Operation Temperature .. -55°C to +105°C

Resistance to

Solder Heat Infrared reflow 230 °C, duration 15 seconds

SOJ Socket

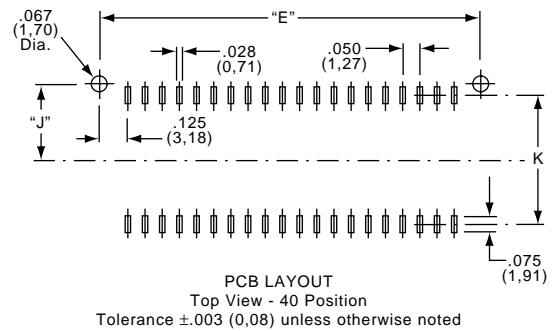
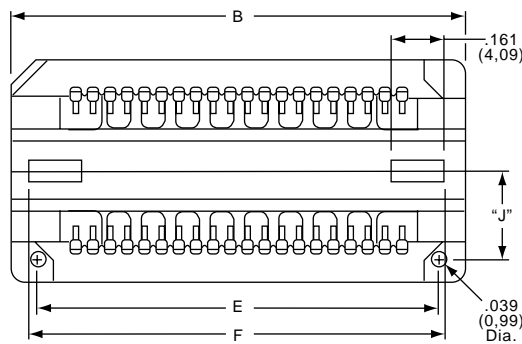
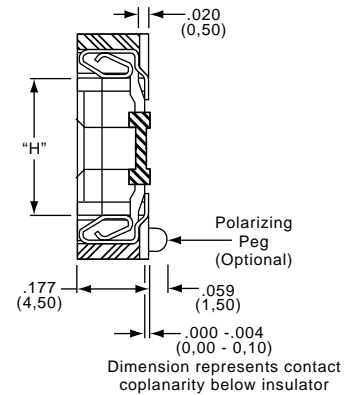
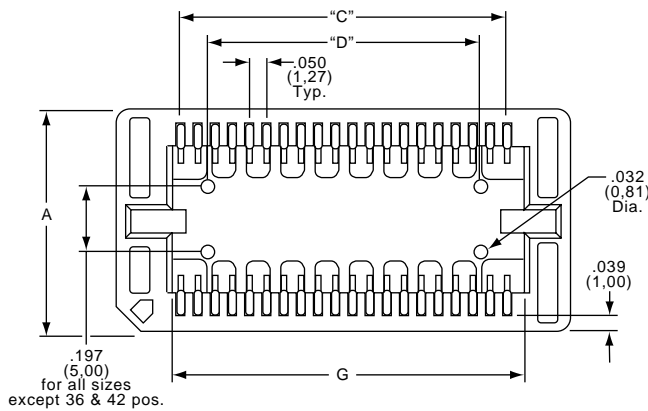

STANDARD CONFIGURATIONS

Number of Pins	A	B	C	D	E	F	G	H	J	K	P/N w/o Pol. Peg	P/N w/ Pol. Peg
24	.546 (13,87)	.916 (23,26)	.550 (13,97)	.500 (12,70)	.800 (20,32)	.852 (21,64)	.644 (16,36)	.325 (8,26)	.210 (5,33)	.300 (7,62)	165-200005-04	165-200005-14
26	.546 (13,87)	.966 (24,53)	.600 (15,24)	.550 (13,97)	.900 (22,86)	.902 (22,91)	.694 (17,63)	.325 (8,26)	.210 (5,33)	.300 (7,62)	165-200005-05	165-200005-15
28	.546 (13,87)	1.016 (25,80)	.650 (16,51)	.600 (15,24)	.900 (22,86)	.952 (24,18)	.744 (18,90)	.325 (8,26)	.210 (5,33)	.300 (7,62)	**165-200005-06	165-200005-16
32	.546 (13,87)	1.116 (28,34)	.750 (19,05)	.700 (17,78)	1.000 (25,40)	1.052 (26,72)	.844 (21,44)	.325 (8,26)	.210 (5,33)	.300 (7,62)	**165-200005-07	165-200005-17
28	.646 (16,40)	1.015 (25,78)	.650 (16,51)	.500 (12,70)	.902 (22,90)	.952 (24,18)	.743 (18,88)	.425 (10,80)	.260 (6,60)	.400 (10,16)	165-200005-03	165-200005-13
32	.646 (16,40)	1.115 (28,32)	.750 (19,05)	.600 (15,24)	1.002 (25,44)	1.052 (26,72)	.843 (21,42)	.425 (10,80)	.260 (6,60)	.400 (10,16)	165-200005-02	165-200005-12
36	.646 (16,40)	1.215 (30,86)	.850 (21,59)	N/A	1.102 (27,98)	N/A	.943 (23,96)	.421 (10,69)	.260 (6,60)	.400 (10,16)	165-200005-08	165-200005-18
40	.646 (16,40)	1.315 (33,40)	.950 (24,13)	.800 (20,32)	1.200 (30,48)	1.252 (31,80)	1.043 (26,50)	.425 (10,80)	.260 (6,60)	.400 (10,16)	**165-200005-01	165-200005-11
42	.646 (16,40)	1.365 (34,67)	1.000 (25,40)	N/A	1.250 (31,75)	N/A	1.093 (27,77)	.421 (10,69)	.260 (6,60)	.400 (10,16)	165-200005-09	165-200005-19

**NOTE: Only P/N 165-200005-01/-06/-07 are available in tape and reel packaging by ordering 165-200005-21/-26/-27. 400 Sockets per reel.

NEW

50 Pin .8mm pitch SOJ socket part number 165-200097-01 (without locating posts)

Need more technical information?

Consult your Thomas & Betts sales office listed on the back cover

C9

Thomas & Betts
1555 Lynnfield Road
Memphis, TN 38119
(901) 682-8221 FAX (901) 537-8805

